

CKT NO.	LOAD DESCRIPTION	VOLTAGE	CONN. LOAD	PHASE BALANCE			CIRCUIT BREAKER POLE-FRAME-TRIP	MCCB Icu kA	CURR -ENT AMP	WIRE SIZE	GROUND SIZE	PIPE mm	REMARK	結線圖
				A	B	C								
R308	3ø4W 110/190V													
1	專插 R1.5KW	110	1500	1500			RCBO 2 50 20	10	13.6	2-5.5	1.6	16ø		
2	軟水器 5A	110	550		550		RCBO 2 50 20	10	5	2-5.5	1.6	16ø		
3	專插 R1.5KW	110	1500			1500	RCBO 2 50 20	10	13.6	2-5.5	1.6	16ø		
4	拌飯機 430W	110	430	430			RCBO 2 50 20	10	3.9	2-5.5	1.6	16ø		
5	專插 R1.5KW	110	1500		1500		RCBO 2 50 20	10	13.6	2-5.5	1.6	16ø		
6	專插 R1.5KW	110	1500			1500	RCBO 2 50 20	10	13.6	2-5.5	1.6	16ø		
7	保溫飯鍋 27A	110	84	84			RCBO 2 50 20	10	0.8	2-5.5	1.6	16ø		
8	專插 R1.5KW	110	1500		1500		RCBO 2 50 20	10	13.6	2-5.5	1.6	16ø		
9	保溫飯鍋 27A	110	84			84	RCBO 2 50 20	10	0.8	2-5.5	1.6	16ø		
10	專插 R1.5KW	110	1500	1500			RCBO 2 50 20	10	13.6	2-5.5	1.6	16ø		
11	專插 R1.5KW	110	1500		1500		RCBO 2 50 20	10	13.6	2-5.5	1.6	16ø		
12	專插 R1.5KW	110	1500			1500	RCBO 2 50 20	10	13.6	2-5.5	1.6	16ø		
13	R180VA-8	110	1440	1440			RCBO 2 50 20	10	13	2-5.5	1.6	16ø		
14	廣告螢幕電視180VA-2	110	360		360		RCBO 2 50 20	10	3.3	2-5.5	1.6	16ø		
15	SPARE	110	*		*		RCBO 2 50 20	10						
16	SPARE	110	*		*		RCBO 2 50 20	10						
17	SPARE	110	*		*		RCBO 2 50 20	10						
	TOTAL	190	14948	4954	5410	4584	3 100 75	10	49.2	XLPE4-22	8.0	E51		

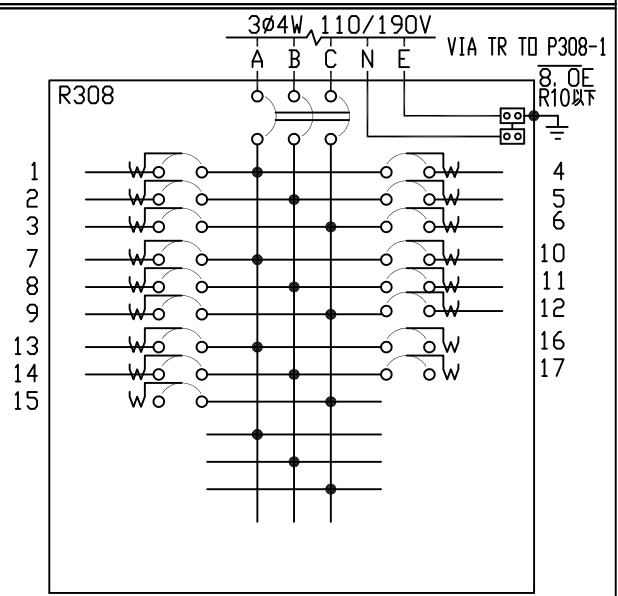

RCBO採30mA0.1S
CU BUS BAR 4-15mmx3mm

客戶 CUSTOMER: 鉅展企業社	核准 APPROVED BY:	審核 CHECKED BY:	設計 DESIGNED BY:	繪圖 DRAWER:	中華機械電氣股份有限公司 CHAN HUA MACHINERY & ELECTRIC CO. LTD. TEL: (04) 23581130 FAX: (04) 23581140 廠址: 台中市南屯區工業 25 路 25 號	版次 REV	修正摘要 SUMMARY	日期 DATE	圖名 TITLE: 系統單線圖	
用途 USER: 國道清水服務區增改建工程	設計課 阮家豪	設計課 阮家豪	設計課 張逸凡	設計課 黃竣清		工號 WORKING NO.: 113071101	規劃日期 DATE: 113年07月17日		圖號 DWG. NO.: A04	版次 REV: A
	<input type="checkbox"/> 保留圖		單位 DIM: 釐米 (mm)	案號 DRAWING NO.:		比例 SCALE: 1:20			張數 SHEET NO.: /	