

CKT NO.	1	2	3	4	5	6	7	8	9	10	11	12	13	14	15	16	17	18	19	TOTAL
CAPACITY(VA)	52970	165780	303797	126000	18540	270000	395800	9964	9964	9570	6764	6794	9570	10684						1396197
CURRENT(A)	80.5	255.7	463.4	192.1	29.5	409.1	615.2	26.0	26.0	25.2	21.5	21.5	25.2	26.0						2122.8
LOAD(VA)	R 17560	53625	101945	42260	6500	90000	13534	1720	1720	5540	720	720	5540	5720						467005
	S 17720	53625	100561	41520	6150	90000	13193	2524	2524	1720	4720	4720	1720	3064						463765
	T 17690	55902	101291	42220	5890	90000	128533	5720	5720	2310	1324	1354	2310	1900						465427
LOAD NAME	TRORRA 機音<55dBa	MLA	EMPA	PA1	PA2	LP6 計分板工程	ACMP	私表WH1A1	私表WHB1	私表WHB2	私表WHB3	私表WHB4	私表WHB5	私表WHB6	SPARE	SPARE	SPARE	SPARE	MPA-SC	P718.5KVA P718.55HP W008KVA L36847KVA

最大使用率80%, 負載 1396197 x 80% = 1116957 VA, I = 1697.1 A (TR 1250KVA 無油風冷可運1562.5KVA)

用途: USER:	虎尾高鐵運動園區(田徑場及暖身場)興建工程	日期 DATE	修正摘要 SUMMARY	建華機電股份有限公司 CHAN HUA MACHINERY & ELECTRIC CO. LTD. TEL:(04)23581130 FAX:(04)23581140	核准 APPROVED:	審核 CHECKED:	設計 DESIGNED:	繪圖 DRAWN:	圖名: TITLE:	系統單線圖				
					工號: WORKING NO.: 113030601	日期: DATE: 113年07月04日				盤名: PANEL:	MPA,MRA,RA1			
					案號: DRAWING NO.: 113	比例: SCALE: 1:20	尺寸單位 DM: 釐米 (mm)			圖號: DWG. NO.: A03	張數: SHEET NO.:	版次: REV:	1	

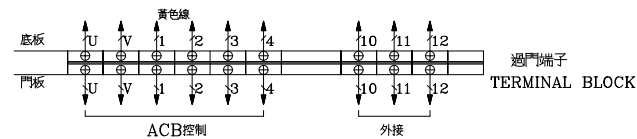
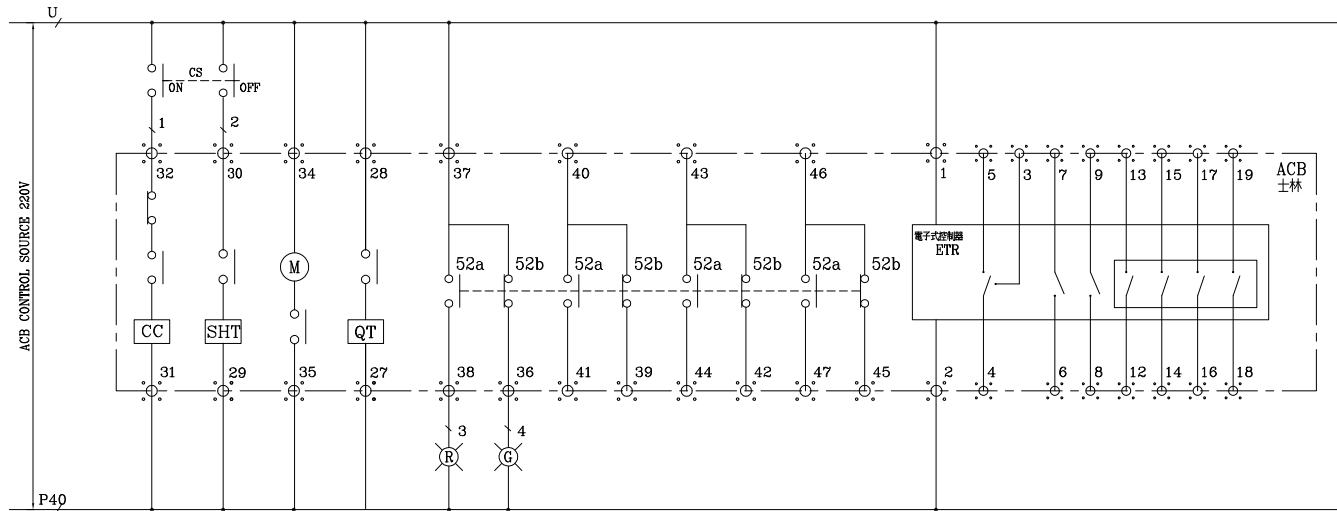

ACB CONTROL SOURCE

SHIHLIN ACB CONTROL
AIR CIRCUIT-BREAKER CONTROL UNIT

- 1.OFF : "Open" pushbutton
- 2.ON : "Close" pushbutton
- 3.M : Spring charging motor(180VA,240V AC)
- 4.CC : Closing Coil(100-120V or 200-240V AC)
- 5.SHT : Shunt trip device (100-120v or 200-240V AC)
- 6.QT : Undervoltage release (100-120V or 200-240V AC)
- 7.52a : Auxiliary switch contact a
- 8.52b : Auxiliary switch contact b

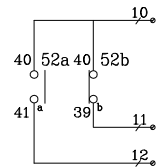

外部監控接點

MPA PANEL
MPB PANEL
MPC PANEL

用途: USER:	虎尾高鐵運動園區(田徑場及暖身場)興建工程	日期 DATE	修正摘要 SUMMARY	盛華機電股份有限公司 CHAN HUA MACHINERY & ELECTRIC CO LTD. TEL:(04)23581130 FAX:(04)23581140	核准 APPROVED:	審核 CHECKED:	設計 DESIGNED:	繪圖 DRAWN:	圖名: TITLE:	系統複線控制圖				
					工號: WORKING NO.: 113030601	日期: DATE: 113年06月12日				盤名: PANEL:	MPA,MPB,MPC			
					案號: DRAWING NO.: 113	比例: SCALE: 1:25	尺寸單位 DM: 釐米 (mm)			圖號: DWG. NO.: C09	張數: SHEET NO.:	版次: REV:	1	

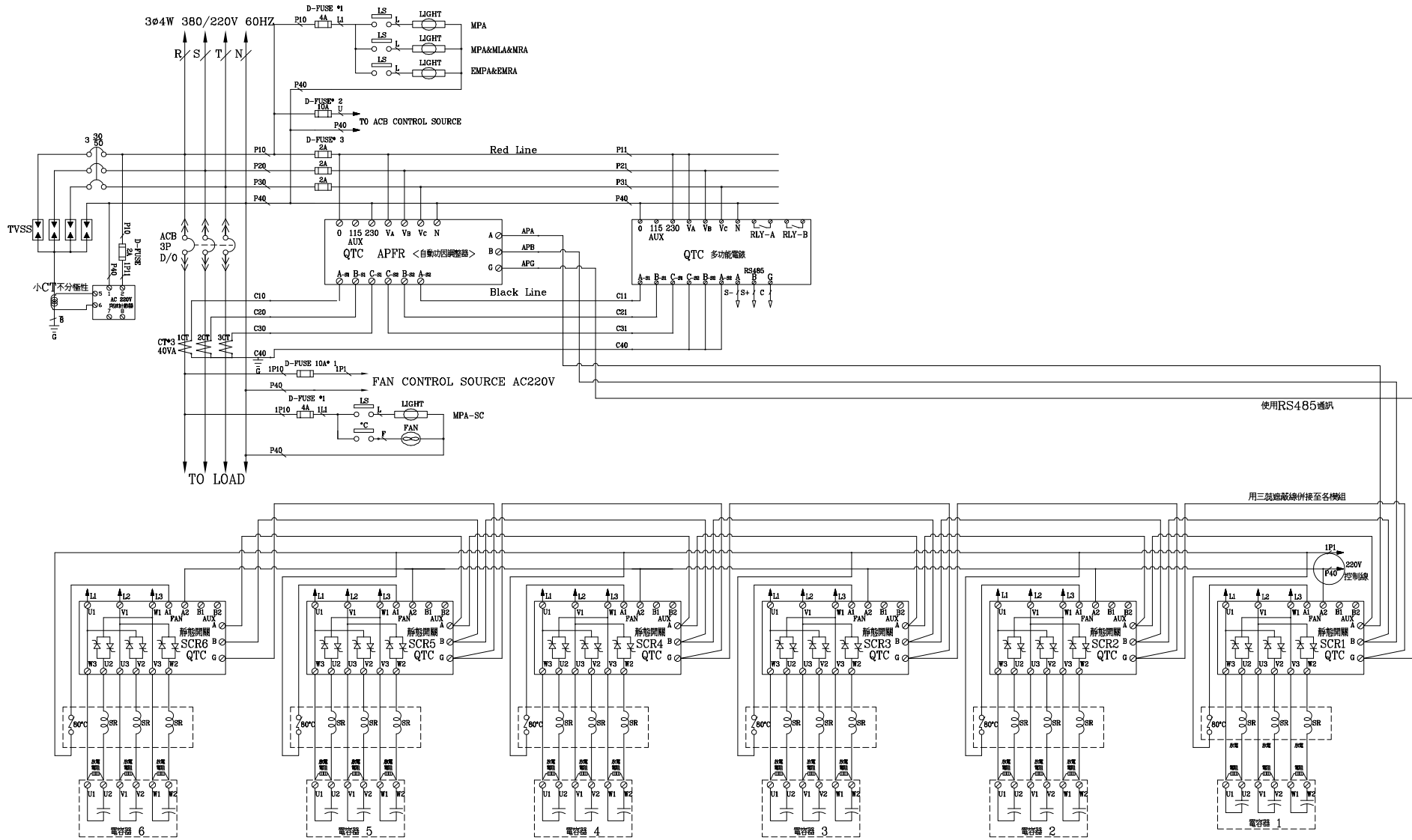

MPA PANEL 儀錶結線圖

用途: USER:	虎尾高鐵運動園區(田徑場及暖身場)興建工程	日期 DATE	修正摘要 SUMMARY	 建華機電股份有限公司 CHAN HUA MACHINERY & ELECTRIC CO. LTD. TEL:(04)23581130 FAX:(04)23581140	核准 APPROVED:	審核 CHECKED:	設計 DESIGNED:	繪圖 DRAWN:	圖名: TITLE:	系統複線及控制圖				
					工號: WORKING NO.: 113030601	日期 DATE: 113年06月12日				盤名: PANEL:	MPA			
					家號: DRAWING NO.: 113	比例 SCALE: 1:25	尺寸單位 DM: 釐米 (mm)			圖號: DWG. NO.: C10	張數: SHEET NO.:	版次: REV:	1	